

domofocus outdoor

© atelier dominique imbert, 2015.



Notice individuelle

Specific instructions
Istruzione individuale
Modellspezifische Hinweise
Individuele instructie
Instrucción individual
Дополнительные инструкции
Supplerende anvisninger
Täiendavad juhised
Mallikohtaiset ohjeet
ατομική κάρτα ενημέρωσης
Τονάββι utasítások
specifiskā instrukcija
Individuali instrukcija
Fisa individuala
Indywidualna instrukcja obsługi
Noticia individual
Dodatočné inštrukcie
Dodatna navodila
Särskilda instruktioner
Individuální návod
Struzzjonijiet addizzjonali
Индивидуална информационна карта

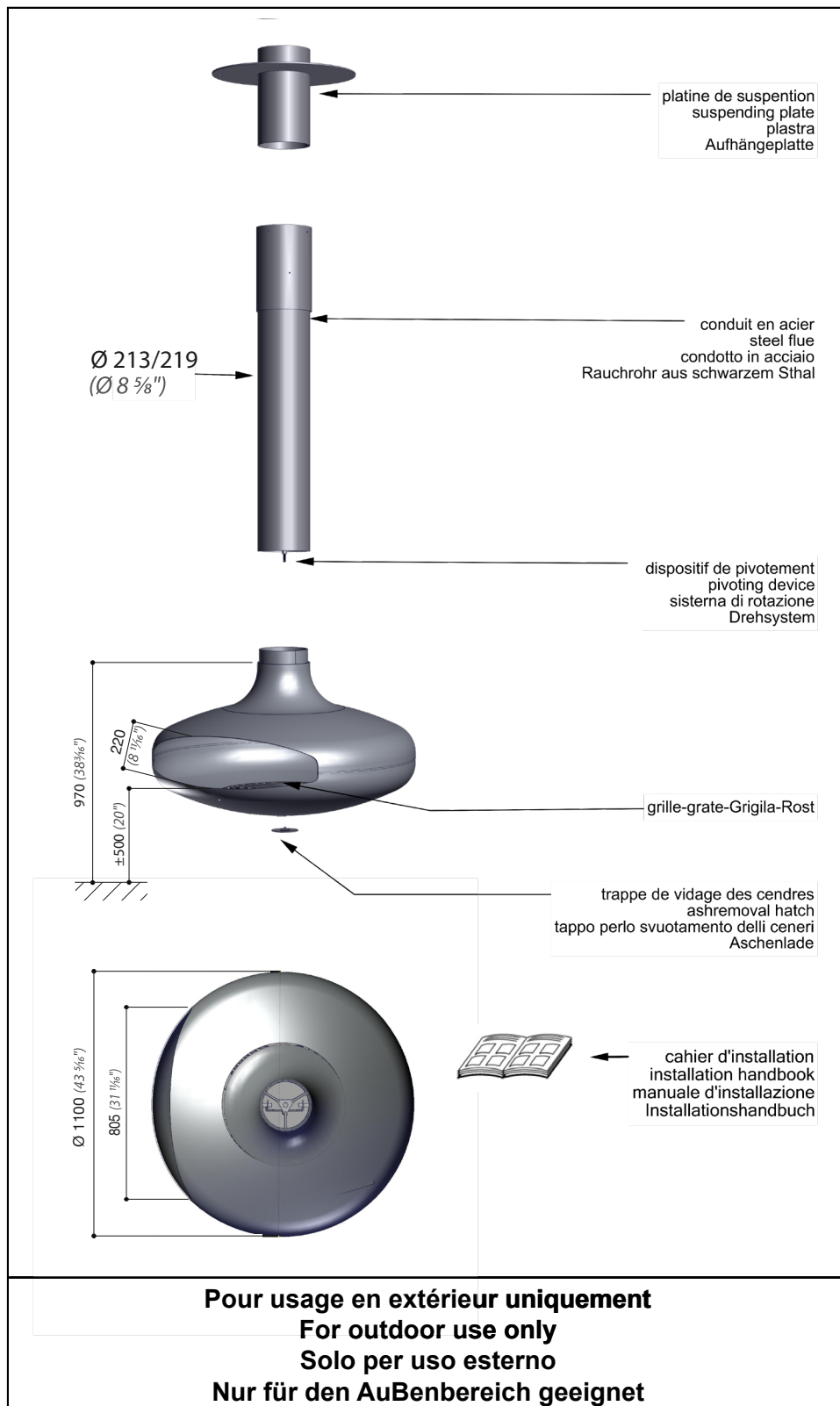

Pour usage en extérieur uniquement
For outdoor use only
Solo per uso esterno
Nur für den Außenbereich geeignet

focus®

Atelier Dominique Imbert s.a.s
34380 Viols le fort - France
téléphone : +33 (0)4 67 55 01 93
télécopie : +33 (0)4 67 55 77 77
info@focus-creation.com
<http://www.focus-creation.com>

12/09/2023

domofocus outdoor

© atelier dominique imbert, 2015.

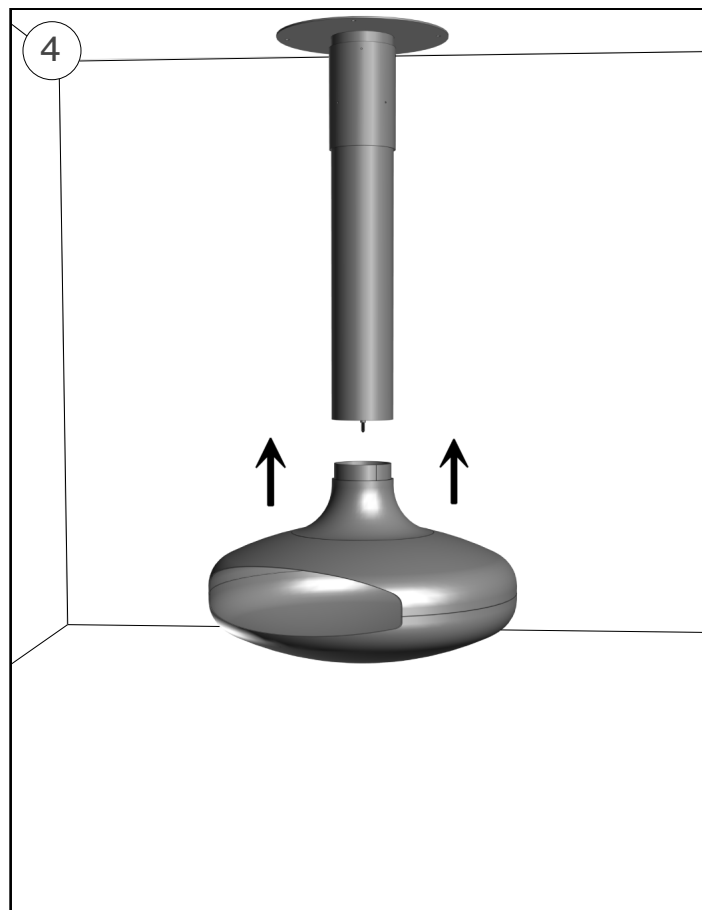
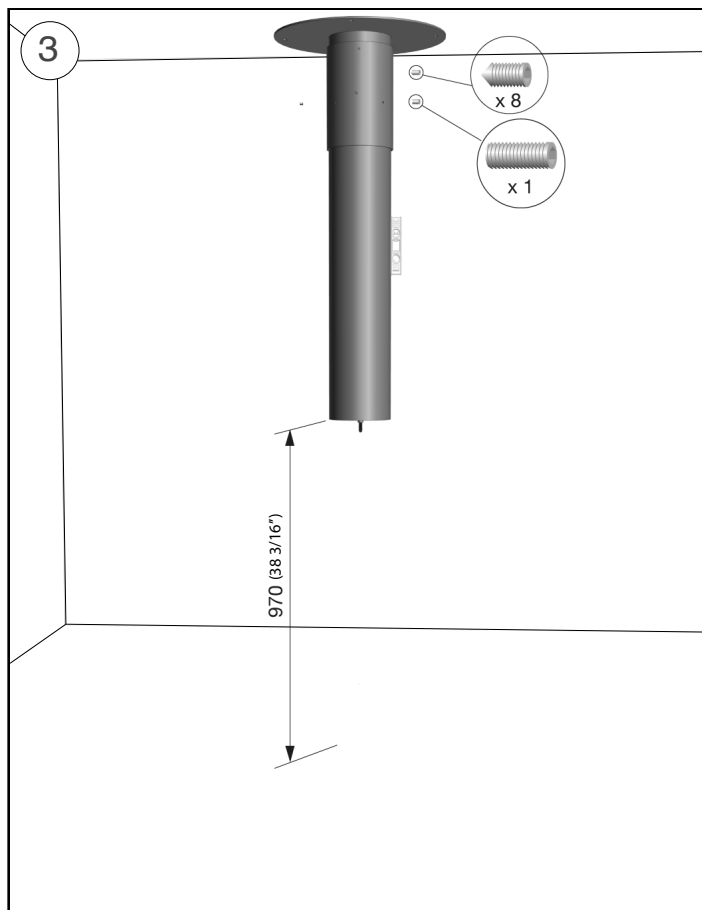
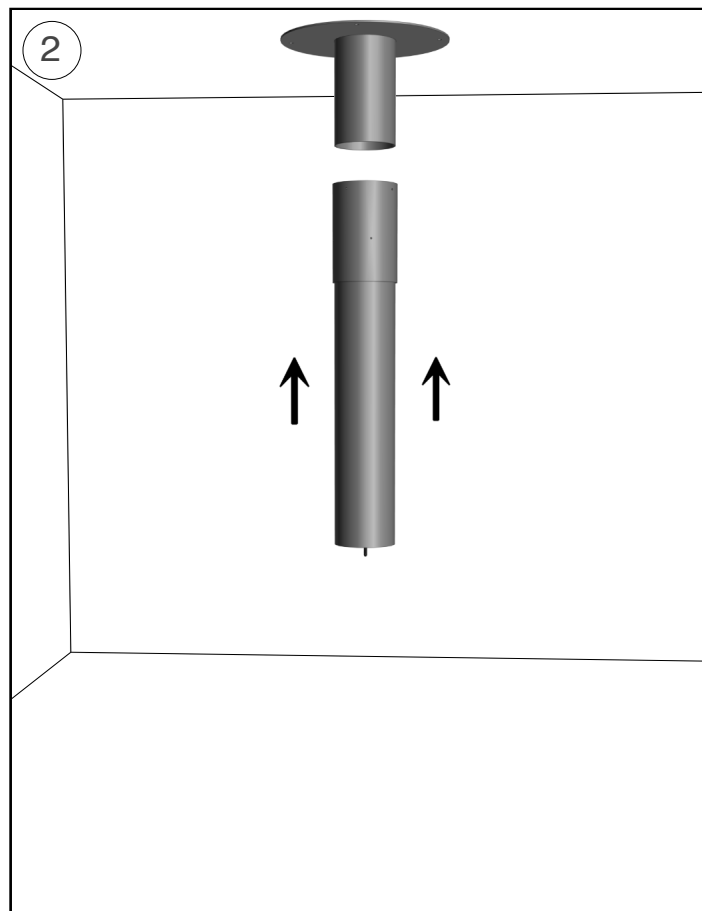
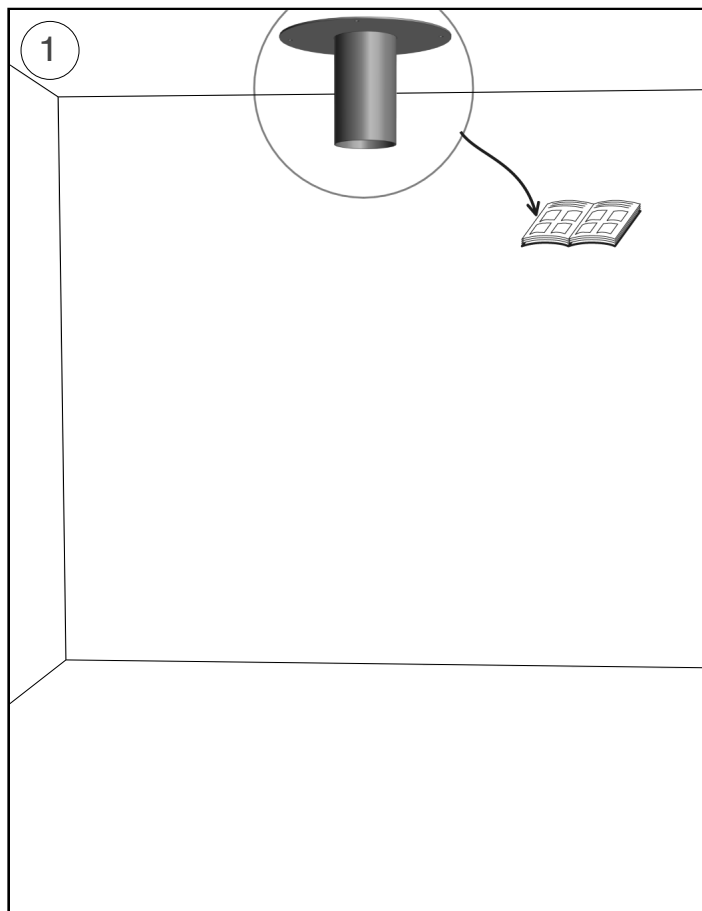

domofocus outdoor

© atelier dominique imbert, 2015.

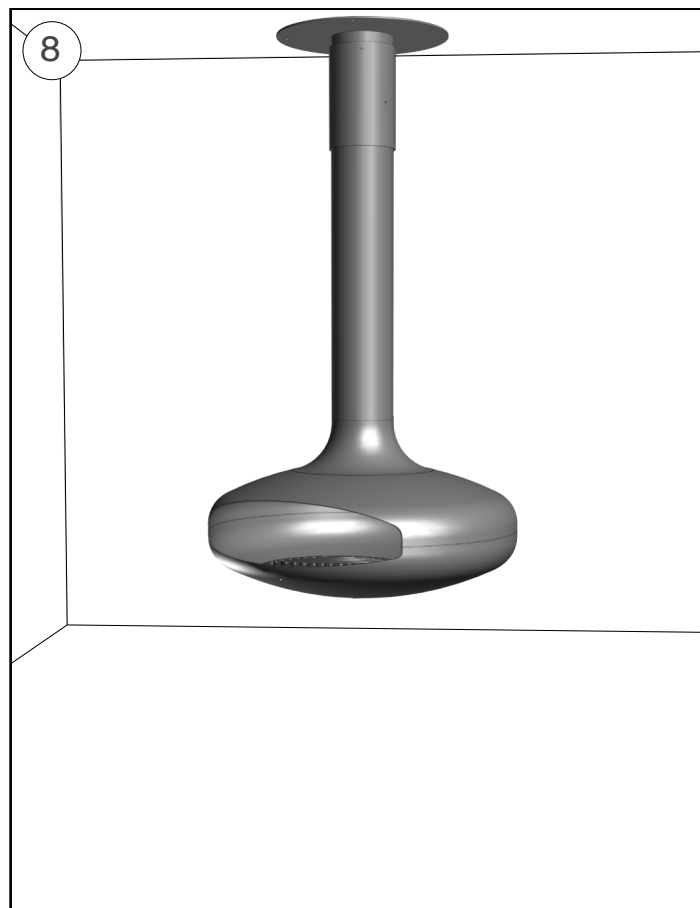
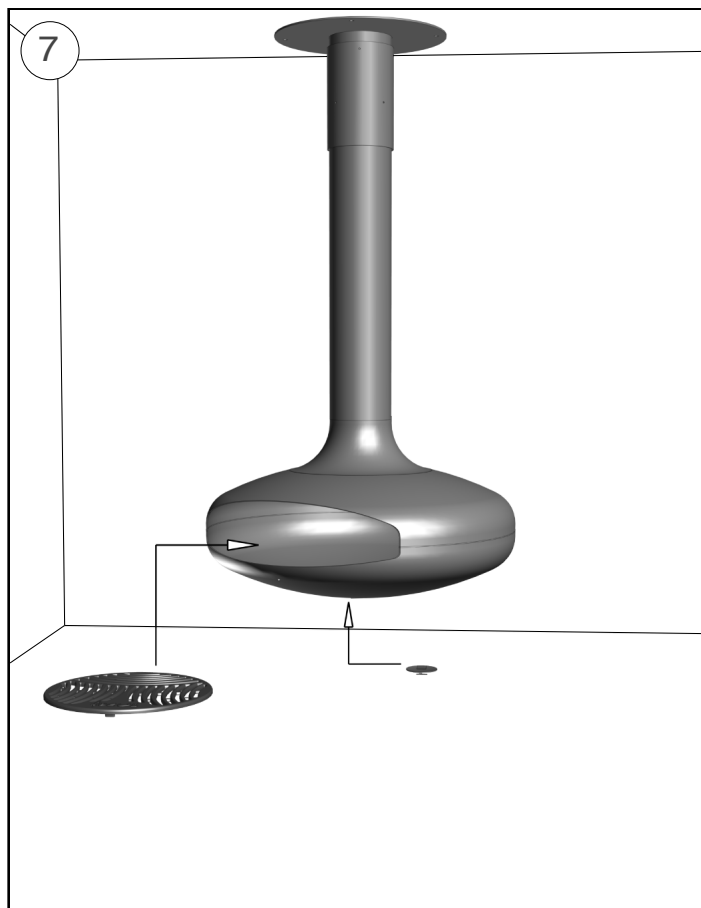
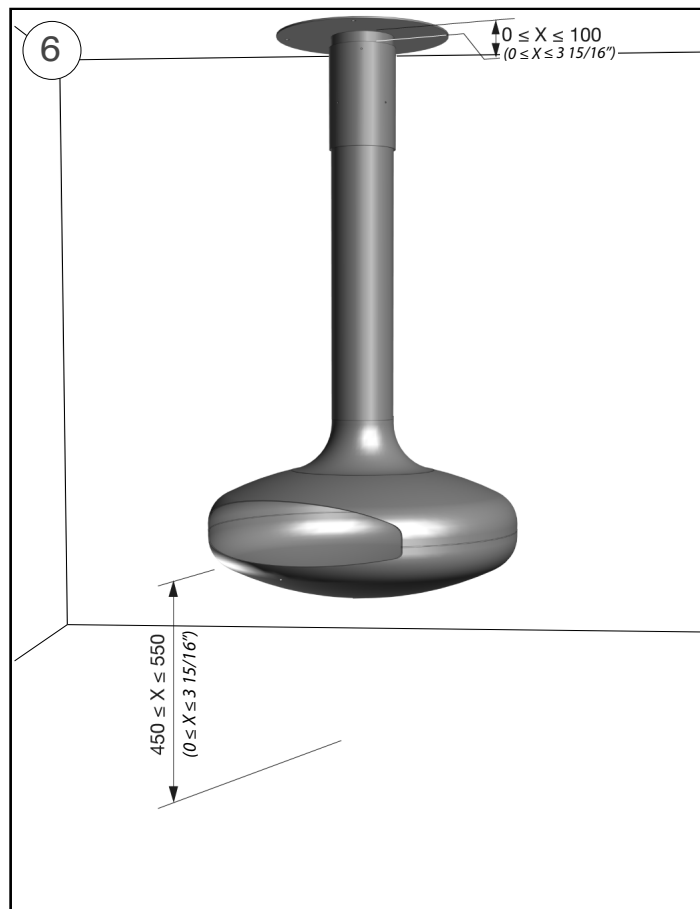
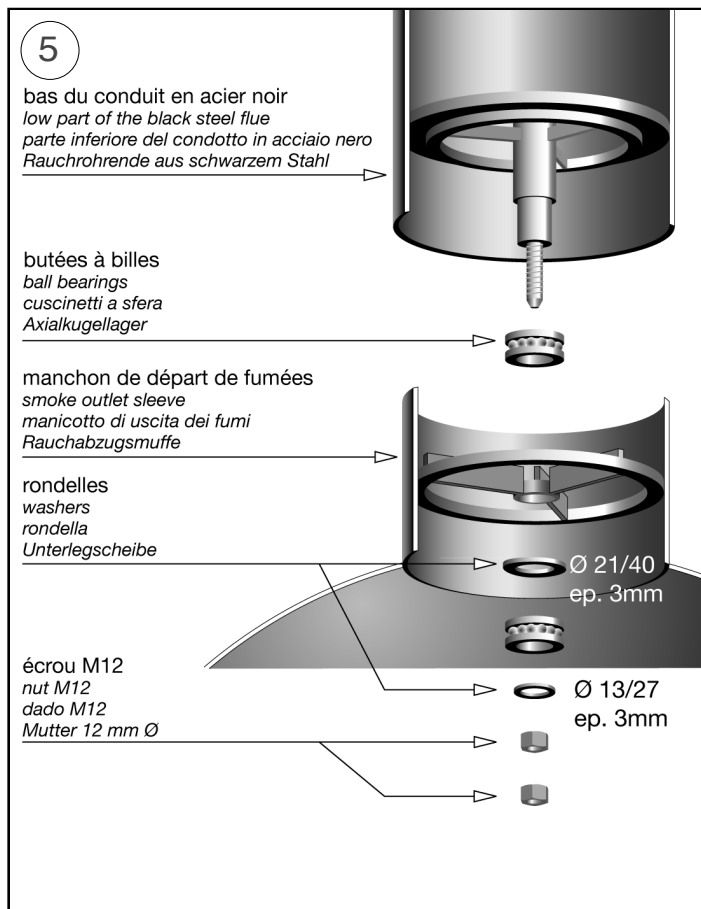

Distances de sécurité par rapport aux matériaux combustibles.

Safety clearance distances from combustible materials.

Mindestabstand hinsichtlich der brennbaren Materialien.

Distanze di sicurezza da ogni materiale combustibile.

distancias de seguridad con relación a los materiales combustibles

Veilige afstand tot brandbaar materiaal.

Sikkerheds afstand til brændbart materiale.

OHUTU KAUGUS
PÖLEVATERJALIDEST.

Suojaetäisyydet palava-aineiseen materiaaliin.

αποστάσεις ασφαλείας από εύφλεκτα υλικά.

Biztonsági távolság gyúlékony anyagoktól.

Droša distance no viegli uzliesmojošiem materiāliem.

Leistinas saugus atstumas nuo degių medžiagų.

Distanzi li jridu jithallew minn kull materjal li jista jaqbad.

Minimalne odległości bezpieczeństwa od materiałów palnych.

Distâncias de segurança em relação aos materiais combustíveis.







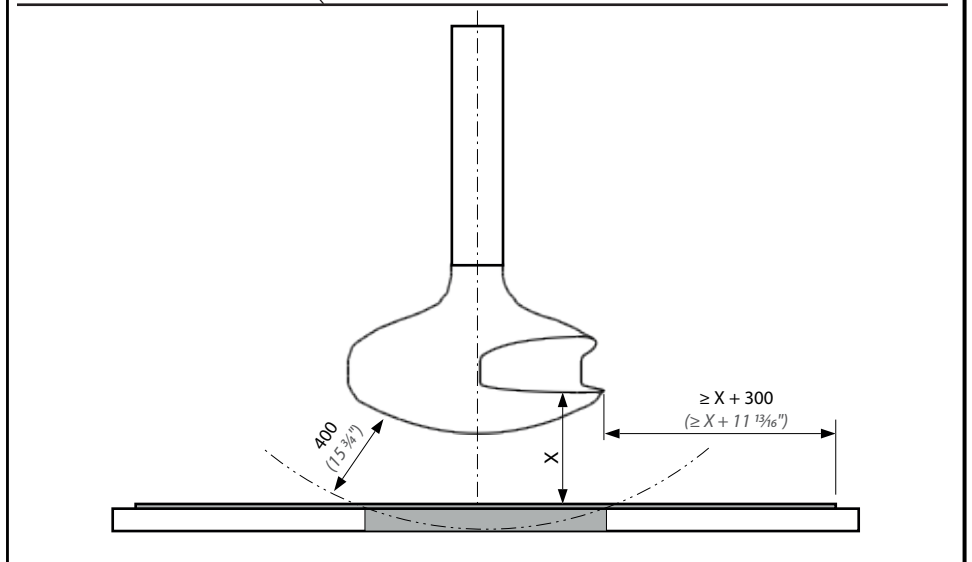
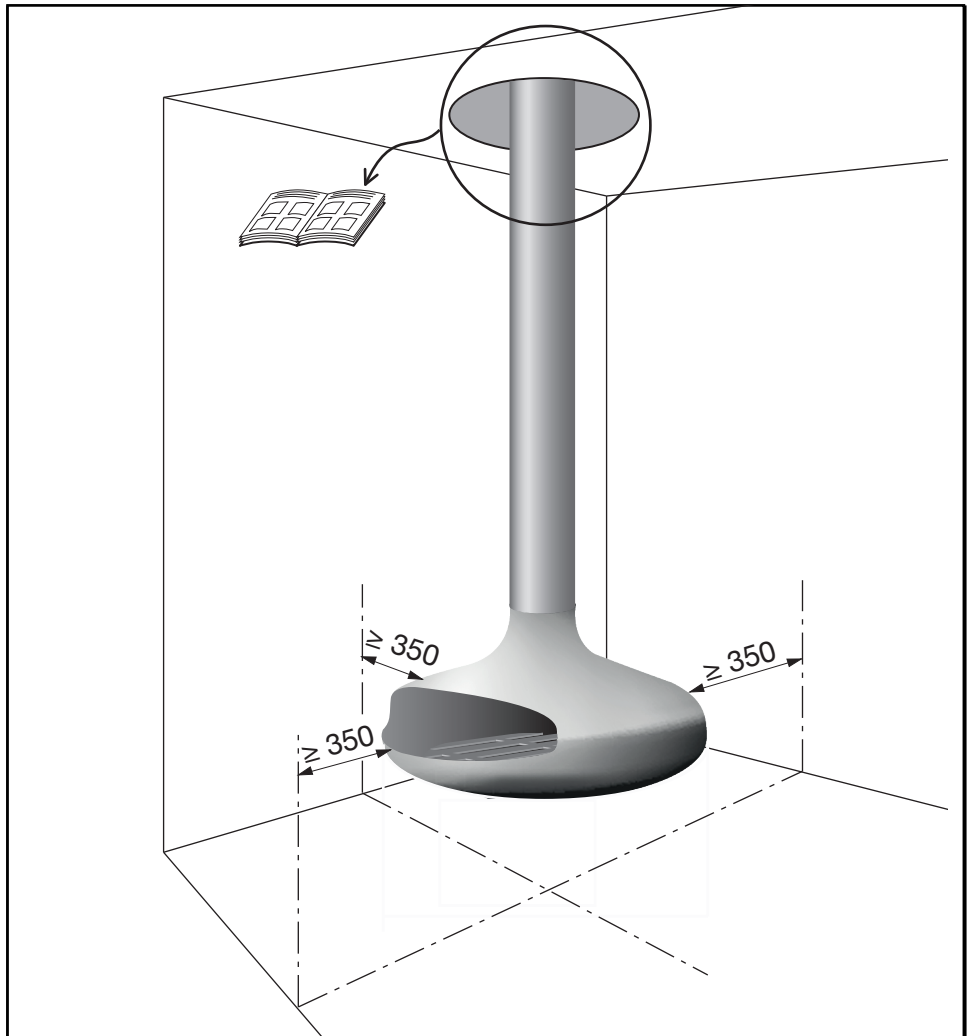

Bezpečnostná vzdialenosť od horľavých materiálov.

Varnostna razdalja glede na vnetljive materiale.

Säkerhetsavstånd från brännbart material.

Bezpečnostní vzdálenost od hořlavých materiálů.



	matériaux combustibles		matériaux incombustibles et non dégradables sous l'effet de la chaleur
	combustible materials		non combustible and heat resistant materials
	materiale combustibili		materiale incombustibili o non degradabili sotto l'effeto del calore
	brennbares Material		nicht brennbares und feuerbeständiges Material